

# 冷凝器

2026

50hz

# HFC

冷凝器

- HCA & HCAS	3
- HCB & HCBS	9
- HCV	17
- HCVD	27

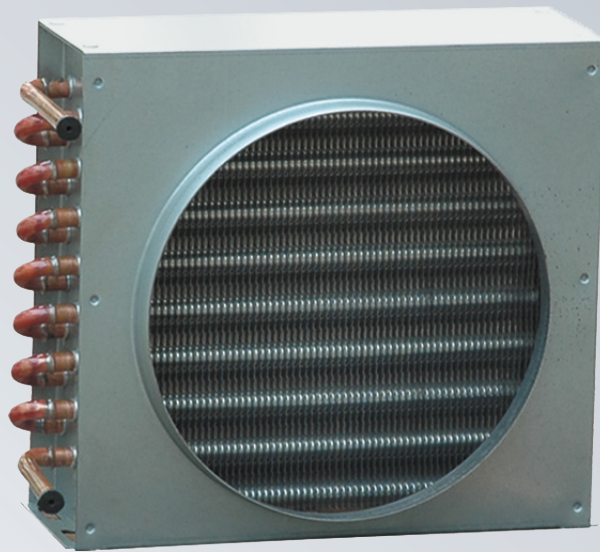

# HCA & HCAS 冷凝器

## HCA & HCAS 冷凝器

HCA 的高效内芯采用铝箔和  $\phi 9.52\text{mm}$  (HCA) 或  $\phi 7\text{mm}$  (HCAS) 内螺纹铜管，通过减少管容积来降低冷媒充注量，满足全球温室气体的减排需求。所有内芯均经过清洁和 30bar 保压测试。  
外壳采用“悬浮”结构，以避免铜管和侧板板之间产生接触，确保冷凝器的使用寿命长且无泄漏。

01 无喷涂的镀锌板外壳，有较高的防腐蚀和抗震性能。

02 可使用“Unit Selector Hybrid HISPANIA”选型软件查询样册以外的工况性能。



更多需求和信息请联系 Hispania。

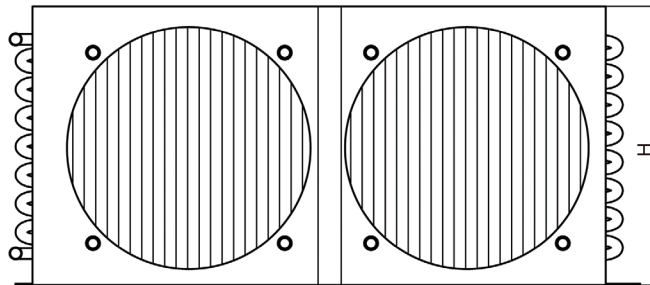
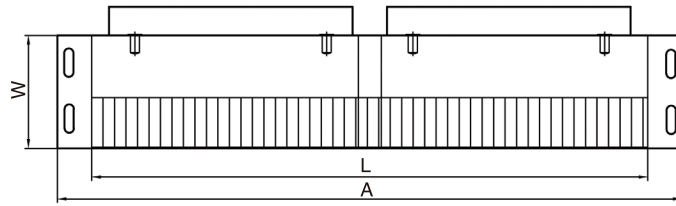
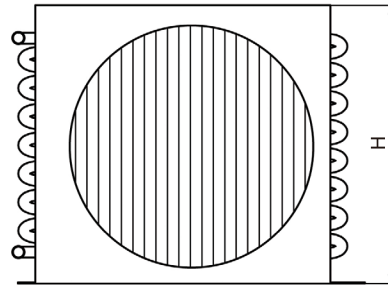
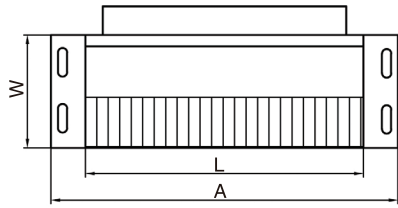

型号	孔数	制冷量 (kW)			片距 (mm)	面积 (m <sup>2</sup> )	风机		尺寸 (mm)				接口尺寸	
		HP	R404A/ R507A	R448A/ R449A			N° × Ø (mm)	风量 (m <sup>3</sup> /h)	A	H	W	L	进	出
			DT1=15K	DT1=15K										
HCA-82	8 × 2	1/5	0.58	0.59	3.5	1.1	1 × 200	365	300	245	100	240	3/8"	3/8"
HCA-83	8 × 3	1/4	0.77	0.77	3.5	1.7	1 × 200	321	300	245	125	240	3/8"	3/8"
HCA-84	8 × 4	1/4	0.86	0.87	3.5	2.3	1 × 200	284	300	245	150	240	3/8"	3/8"
HCA-92	9 × 2	1/4	0.87	0.88	3.5	1.5	1 × 250	568	330	285	100	270	3/8"	3/8"
HCA-93	9 × 3	1/3	1.15	1.16	3.5	2.2	1 × 250	499	360	285	125	270	3/8"	3/8"
HCA-94	9 × 4	3/8	1.32	1.33	3.5	2.9	1 × 250	453	340	285	150	270	3/8"	3/8"
HCA-103	10 × 3	1/3	1.43	1.44	3.5	3.2	1 × 250	480	330	285	125	270	3/8"	3/8"
HCA-104	10 × 4	3/8	1.43	1.44	3.5	3.2	1 × 250	480	330	285	150	270	3/8"	3/8"
HCA-114	11 × 4	1/2	1.66	1.67	3.5	3.9	1 × 250	538	370	290	150	300	3/8"	3/8"
HCA-124A	12 × 4	1/2	1.68	1.69	3.5	4.3	1 × 250	563	370	315	150	300	5/8"	1/2"
HCA-124B	12 × 4	5/8	2.95	2.98	3.5	5	1 × 300	1143	435	365	150	350	5/8"	1/2"
HCA-143	14 × 3	5/8	2.78	2.81	3.5	4.4	1 × 300	1322	445	365	150	350	5/8"	1/2"
HCA-144	14 × 4	5/8	3.31	3.34	3.5	5.9	1 × 300	1233	435	365	150	350	5/8"	1/2"
HCA-145	14 × 5	3/4	3.32	3.36	3.5	7.3	1 × 300	1155	440	365	175	350	3/4"	5/8"
HCA-163	16 × 3	7/8	4.53	4.58	3.5	6.2	1 × 350	2366	515	420	150	430	5/8"	1/2"
HCA-164A	16 × 4	1	5.29	5.35	3.5	8.2	1 × 350	2202	520	420	150	430	3/4"	5/8"
HCA-164B	16 × 4	1.25	6.2	6.26	3.5	8.6	1 × 400	2705	540	465	200	450	3/4"	5/8"
HCA-165	16 × 5	1.5	6.7	6.77	3.5	10.7	1 × 400	2455	540	465	200	450	3/4"	5/8"
HCA-185	18 × 5	1.75	8.11	8.19	3.5	13.4	1 × 400	2841	590	465	200	500	3/4"	5/8"
HCA-104D	10 × 4	7/8	2.87	2.89	3.5	6.4	2 × 250	960	625	285	150	540	5/8"	1/2"
HCA-114D	11 × 4	7/8	3.32	3.34	3.5	7.9	2 × 250	1075	685	290	150	600	5/8"	1/2"
HCA-124D	12 × 4	1.25	5.91	5.97	3.5	10	2 × 300	2285	790	365	150	700	3/4"	5/8"
HCA-100S	14 × 3	1.5	6.72	6.78	2.5	11.9	2 × 300	2533	785	365	150	700	5/8"	1/2"
HCA-150K	14 × 4	1.8	7.48	7.54	2.5	15.9	2 × 300	2334	785	365	150	700	3/4"	5/8"
HCA-200L	16 × 3	2	10.75	10.85	2.5	15.6	2 × 350	4378	885	420	150	800	5/8"	1/2"
HCA-200S	18 × 3	2.5	11.58	11.69	2.5	17.5	2 × 350	4601	885	470	200	800	5/8"	1/2"
HCA-300S	18 × 4	3	13.14	13.25	2.5	23.4	2 × 350	4275	885	470	200	800	3/4"	5/8"
HCA-400E	20 × 4	3.5	16.38	16.5	2.5	34.9	2 × 350	5056	1180	520	200	1075	1-1/8"	3/4"
HCA-400S	20 × 4	4	19.12	19.28	2.5	34.9	2 × 400	6248	1180	520	200	1075	1-1/8"	7/8"
HCA-500T	22 × 5	5	21.67	21.83	2.5	48	2 × 400	6145	1190	600	230	1075	1-3/8"	7/8"
HCA-500S	22 × 5	7.5	28.15	28.38	2.5	48	2 × 450	8705	1190	600	230	1075	1-3/8"	7/8"
HCA-600T	22 × 5	9	34.45	34.75	2.5	53.1	2 × 500	10989	1305	600	230	1190	1-3/8"	7/8"
HCA-285	28 × 5	10	40.9	41.24	2.5	67.6	2 × 500	12698	1305	730	230	1190	1-3/8"	7/8"
HCA-286	28 × 6	15	66.67	67.42	2.5	102.3	2 × 630	20153	1645	740	400	1500	1-3/8"	7/8"
HCA-346	34 × 6	20	80.11	81	2.5	124.2	2 × 630	24105	1650	890	400	1500	1-3/8"	7/8"

型号	孔数	制冷量 (kW)			片距 (mm)	面积 (m <sup>2</sup> )	风机		尺寸 (mm)				接口尺寸	
		HP	R404A/ R507A	R448A/ R449A			N° × Ø (mm)	风量 (m <sup>3</sup> /h)	A	H	W	L	进	出
			DT1=15K	DT1=15K										
HCAS-82	8 × 2	1/5	0.57	0.57	3.5	1.2	1 × 200	352	300	245	100	240	3/8"	3/8"
HCAS-83	8 × 3	1/4	0.71	0.72	3.5	1.8	1 × 200	299	300	245	125	240	3/8"	3/8"
HCAS-84	8 × 4	1/4	0.79	0.8	3.5	2.4	1 × 200	264	300	245	150	240	3/8"	3/8"
HCAS-92	9 × 2	1/4	0.82	0.83	3.5	1.5	1 × 250	539	330	285	100	270	3/8"	3/8"
HCAS-93	9 × 3	1/3	1.06	1.07	3.5	2.3	1 × 250	471	360	285	125	270	3/8"	3/8"
HCAS-94	9 × 4	3/8	1.21	1.22	3.5	3	1 × 250	426	340	285	150	270	3/8"	3/8"
HCAS-103	10 × 3	1/3	1.3	1.32	3.5	3.3	1 × 250	454	330	285	125	270	3/8"	3/8"
HCAS-104	10 × 4	3/8	1.3	1.32	3.5	3.3	1 × 250	454	330	285	150	270	3/8"	3/8"
HCAS-114	11 × 4	1/2	1.5	1.51	3.5	4.1	1 × 250	509	370	290	150	300	3/8"	3/8"
HCAS-124A	12 × 4	1/2	1.57	1.58	3.5	4.5	1 × 250	534	370	315	150	300	5/8"	1/2"
HCAS-124B	12 × 4	5/8	2.7	2.72	3.5	5.2	1 × 300	1079	435	365	150	350	5/8"	1/2"
HCAS-143	14 × 3	5/8	2.58	2.6	3.5	4.5	1 × 300	1273	445	365	150	350	5/8"	1/2"
HCAS-144	14 × 4	5/8	3.02	3.05	3.5	6.1	1 × 300	1174	435	365	150	350	5/8"	1/2"
HCAS-145	14 × 5	3/4	3.15	3.19	3.5	7.6	1 × 300	1095	440	365	175	350	3/4"	5/8"
HCAS-163	16 × 3	7/8	4.18	4.22	3.5	6.4	1 × 350	2268	515	420	150	430	5/8"	1/2"
HCAS-164A	16 × 4	1	4.91	4.95	3.5	8.5	1 × 350	2102	520	420	150	430	3/4"	5/8"
HCAS-164B	16 × 4	1.25	5.61	5.66	3.5	8.9	1 × 400	2513	540	465	200	450	3/4"	5/8"
HCAS-165	16 × 5	1.5	6.09	6.14	3.5	11.1	1 × 400	2269	540	465	200	450	3/4"	5/8"
HCAS-185	18 × 5	1.75	7.41	7.48	3.5	13.9	1 × 400	2686	590	465	200	500	3/4"	5/8"
HCAS-104D	10 × 4	7/8	2.63	2.64	3.5	6.7	2 × 250	907	625	285	150	540	5/8"	1/2"
HCAS-114D	11 × 4	7/8	3.02	3.04	3.5	8.2	2 × 250	1017	685	290	150	600	5/8"	1/2"
HCAS-124D	12 × 4	1.25	5.42	5.47	3.5	10.4	2 × 300	2157	790	365	150	700	3/4"	5/8"
HCAS-100S	14 × 3	1.5	6.13	6.19	2.5	12.5	2 × 300	2414	785	365	150	700	5/8"	1/2"
HCAS-150K	14 × 4	1.8	6.89	6.95	2.5	12.4	2 × 300	2414	785	365	150	700	3/4"	5/8"
HCAS-200L	16 × 3	2	9.32	9.47	2.5	16.3	2 × 350	4164	885	420	150	800	5/8"	1/2"
HCAS-200S	18 × 3	2.5	9.91	10.1	2.5	18.3	2 × 350	4406	885	470	200	800	5/8"	1/2"
HCAS-300S	18 × 4	3	11.41	11.59	2.5	24.4	2 × 350	4031	885	470	200	800	3/4"	5/8"
HCAS-400E	20 × 4	3.5	15.15	15.28	2.5	36.5	2 × 350	4856	1180	520	200	1075	1-1/8"	3/4"
HCAS-400S	20 × 4	4	17.43	17.61	2.5	36.5	2 × 400	5959	1180	520	200	1075	1-1/8"	7/8"
HCAS-500T	22 × 5	5	20	20.15	2.5	50.2	2 × 400	5853	1190	600	230	1075	1-3/8"	7/8"
HCAS-500S	22 × 5	7.5	25.2	25.47	2.5	50.2	2 × 450	8131	1190	600	230	1075	1-3/8"	7/8"
HCAS-600T	22 × 5	9	30.11	30.5	2.5	55.5	2 × 500	10184	1305	600	230	1190	1-3/8"	7/8"
HCAS-285	28 × 5	10	36.44	36.88	2.5	70.7	2 × 500	11993	1305	730	230	1190	1-3/8"	7/8"
HCAS-286	28 × 6	15	53.02	54.34	2.5	106.9	2 × 630	18220	1645	740	400	1500	1-3/8"	7/8"
HCAS-346	34 × 6	20	64.39	66	2.5	129.8	2 × 630	22134	1650	890	400	1500	1-3/8"	7/8"

# 选配



## 铜管

- $\varnothing 9.52$  mm 内螺纹铜管
- $\varnothing 7$  mm 内螺纹铜管



## 钣金

- 按客户需求喷涂

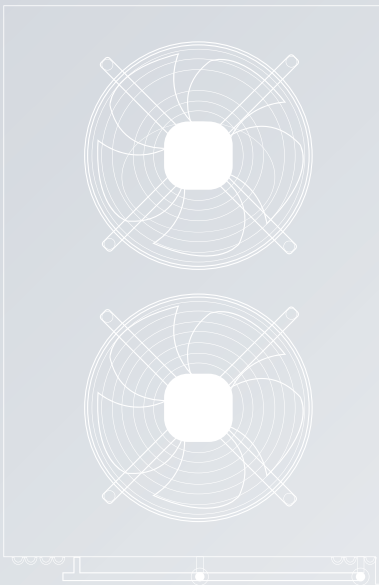
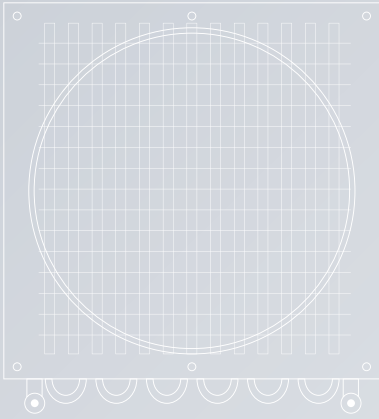
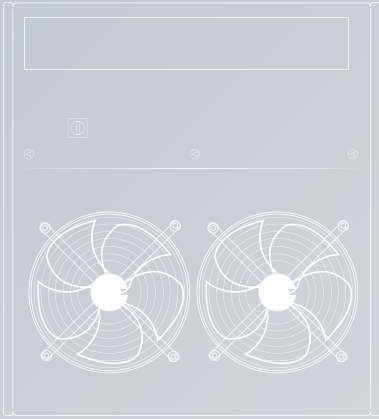
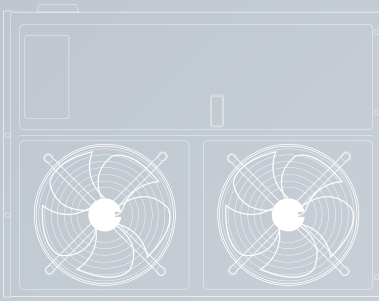

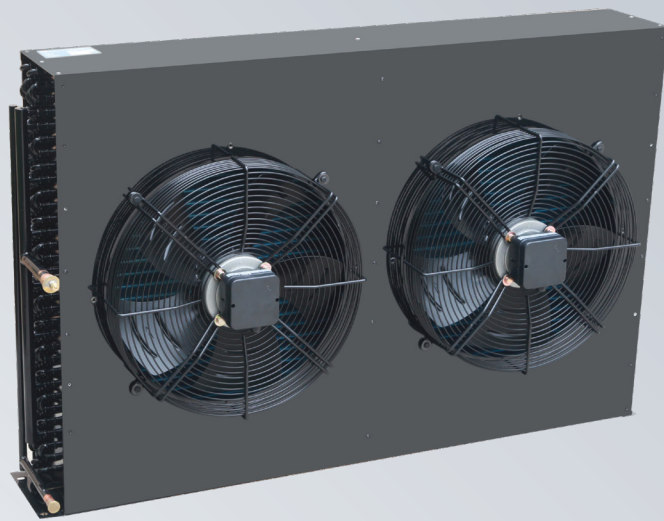

# HCB & HCBS 冷凝器

## HCB & HCBS 冷凝器

HCB 的高效内芯采用铝箔和  $\phi 9.52\text{mm}$ (HCB) 或  $\phi 7\text{mm}$ (HCBS) 内螺纹铜管，通过减少管容积来降低冷媒充注量，满足全球温室气体的减排需求。所有内芯均经过清洁和 30bar 保压测试。

外壳采用“悬浮”结构，以避免铜管和侧板板之间产生接触，确保冷凝器的使用寿命长且无泄漏。

在室外设备上，蓝色翅片有助于保护部件免受腐蚀。

01 黑色喷涂的镀锌板外壳，有较高的防腐蚀和抗震性能。

02 可使用“Unit Selector Hybrid HISPANIA”选型软件查询样册以外的工况性能。



更多需求和信息请联系 Hispania。

# HCB - 1CD

● 风机数量 (空白: 单风机, CD: 双风机, FD: 四风机)

● 系列



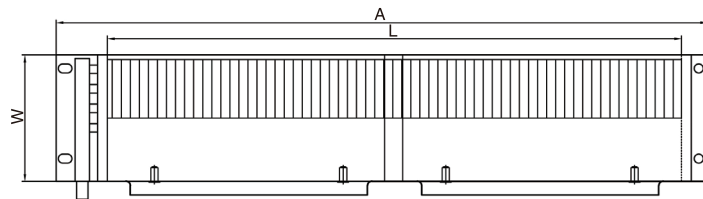
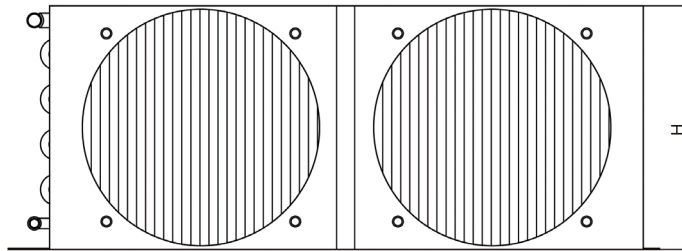
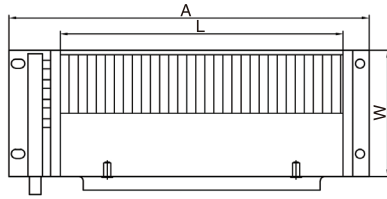
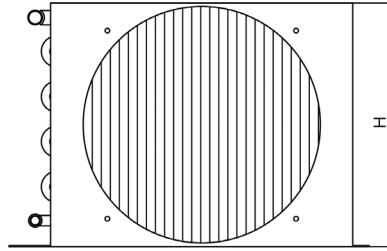

型号	孔数	制冷量 (kW)		片距 (mm)	面积 (m <sup>2</sup> )	风机			尺寸 (mm)				接口尺寸	
		R404A/ R507A	R448A/ R449A			N° × ϕ (mm)	极数	风量 (m <sup>3</sup> /h)	A	H	W	L	进	出
		DT1=15K	DT1=15K											
HCB-1/4	2 × 11	1.38	1.39	3.17	2.1	1 × 250	4	739	390	280	100	300	3/8"	3/8"
HCB-1/3	3 × 10	1.60	1.62	3.17	2.9	1 × 250	4	578	375	280	120	300	3/8"	3/8"
HCB-1/2	4 × 10	1.62	1.64	3.17	3.8	1 × 250	4	497	380	280	140	290	3/8"	3/8"
HCB-3/4	4 × 12	3.08	3.11	3.17	5.4	1 × 300	4	1001	445	370	150	350	3/8"	3/8"
HCB-1	4 × 14	3.77	3.80	3.17	7.3	1 × 300	4	1189	490	370	192	400	1/2"	3/8"
HCB-1.5	4 × 16	6.40	6.46	3.17	10.4	1 × 350	4	2147	590	420	192	500	1/2"	3/8"
HCB-2	4 × 18	8.74	8.81	3.2	14.0	1 × 400	4	2911	690	470	192	600	1/2"	3/8"
HCB-2.5	5 × 18	9.69	9.77	3.2	17.5	1 × 400	4	3054	710	470	233	600	5/8"	1/2"
HCB-3	6 × 18	10.17	10.26	3.2	21.0	1 × 400	4	2719	710	470	255	600	5/8"	1/2"
HCB-4	6 × 22	11.49	11.58	3.2	25.7	1 × 400	4	3893	710	570	255	600	5/8"	1/2"
HCB-5	4 × 30	18.61	18.77	2.8	34.5	1 × 500	4	7451	910	780	233	800	5/8"	1/2"
HCB-6	4 × 32	24.31	24.55	2.83	45.4	1 × 500	4	8527	1090	830	233	980	3/4"	5/8"
HCB-7	4 × 36	39.25	39.68	2.83	52.1	1 × 630	4	16049	1118	930	238	1000	7/8"	3/4"
HCB-7	4 × 36	25.30	25.53	2.83	52.1	1 × 630	6	8509	1118	930	238	1000	7/8"	3/4"
HCB-8	4 × 42	32.96	33.36	2.83	60.8	1 × 710	6	12186	1124	1080	334	1000	1-1/8"	7/8"
HCB-9	5 × 42	35.42	35.78	2.83	68.4	1 × 710	6	11398	1024	1080	356	900	1-1/8"	7/8"
HCB-10	4 × 48	47.96	48.43	2.83	74.4	1 × 800	6	17991	1194	1230	334	1070	1-1/8"	7/8"
HCB-1CD	4 × 10	2.23	2.25	3.2	6.5	2 × 200	4	567	590	270	192	500	3/8"	3/8"
HCB-1.5CD	4 × 11	4.21	4.24	3.2	9.4	2 × 250	4	1124	730	305	192	660	1/2"	3/8"
HCB-2CD	4 × 12	6.95	7.02	3.2	12.4	2 × 300	4	2111	895	370	192	800	1/2"	3/8"
HCB-3CD	4 × 16	13.47	13.59	2.8	23.0	2 × 350	4	4166	1090	420	212	1000	5/8"	1/2"
HCB-4CD	4 × 20	15.27	15.42	2.8	28.7	2 × 350	4	4608	1110	525	212	1000	5/8"	1/2"
HCB-5CD	4 × 24	19.60	19.75	2.8	34.5	2 × 400	4	6123	1110	625	233	1000	5/8"	1/2"
HCB-6CD	4 × 26	22.01	22.19	2.8	44.8	2 × 400	4	6763	1310	670	233	1200	5/8"	1/2"
HCB-7.5CD	4 × 32	33.66	34.01	2.8	55.2	2 × 450	4	10980	1310	830	233	1200	7/8"	5/8"
HCB-10CD	4 × 32	46.44	46.82	2.8	73.6	2 × 500	4	15266	1765	830	233	1600	1-1/8"	7/8"
HCB-12CD	4 × 36	71.01	71.75	2.8	82.8	2 × 630	4	27116	1765	928	238	1600	1-1/8"	7/8"
HCB-12CD	4 × 36	46.04	46.44	2.8	82.8	2 × 630	6	15699	1765	928	238	1600	1-1/8"	7/8"
HCB-15CD	4 × 36	76.88	77.64	2.8	93.1	2 × 630	4	28618	1965	928	238	1800	1-1/8"	7/8"
HCB-15CD	4 × 36	49.53	49.92	2.8	93.1	2 × 630	6	16396	1965	928	238	1800	1-1/8"	7/8"
HCB-18CD	4 × 36	66.82	67.37	2.5	113.1	3 × 500	4	22258	2145	928	238	1980	1-1/8"	7/8"
HCB-20CD	4 × 42	71.85	72.44	2.8	123.4	2 × 710	6	23071	2175	1078	334	2000	1-3/8"	1-1/8"
HCB-25CD	4 × 42	75.05	75.69	2.8	132.8	2 × 710	6	23724	2375	1078	334	2200	1-3/8"	1-1/8"
HCB-30CD	5 × 42	82.10	82.85	2.8	167.3	2 × 710	6	31838	2335	1078	350	2200	1-5/8"	1-3/8"
HCB-12FD	3 × 56	50.53	51.36	2.54	80.6	4 × 450	4	23318	1355	1410	400	1200	1-1/8"	7/8"
HCB-15FD	4 × 56	62.41	63.10	2.54	107.5	4 × 450	4	22112	1355	1410	400	1200	1-1/8"	7/8"
HCB-40FD	4 × 84	153.09	154.59	2.1	320.9	4 × 710	6	47552	2178	2128	334	2000	1-5/8"	1-3/8"
HCB-50FD	4 × 84	161.30	162.73	2.1	353	4 × 710	6	48738	2378	2128	334	2200	2-1/8"	1-5/8"
HCB-60FD	5 × 96	235.20	237.25	2.1	504.3	4 × 800	6	66880	2414	2430	350	2200	2-1/8"	1-5/8"

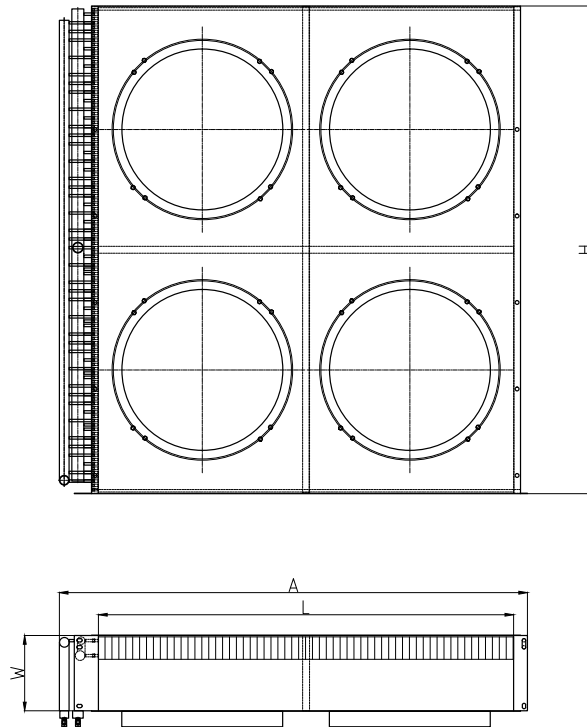
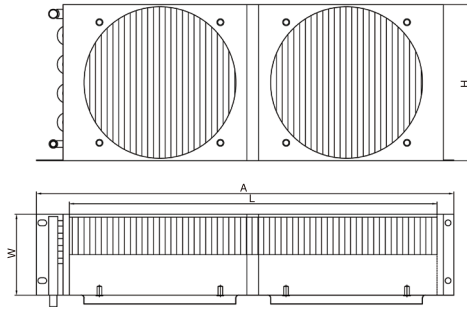
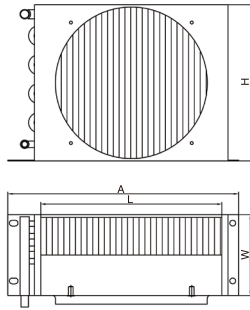

型号	孔数	制冷量 (kW)		片距 (mm)	面积 (m <sup>2</sup> )	风机			尺寸 (mm)				接口尺寸	
		R404A/ R507A	R448A/ R449A			N° × ϕ (mm)	极数	风量 (m <sup>3</sup> /h)	A	H	W	L	进	出
		DT1=15K	DT1=15K											
HCBS-1/6	2 × 6	0.40	0.41	3.17	0.9	1 × 200	4	264	220	154	45	260	3/8"	3/8"
HCBS-1/5	2 × 8	0.54	0.55	3.17	1.2	1 × 200	4	325	220	204	45	260	3/8"	3/8"
HCBS-1/4	2 × 11	1.42	1.43	2.54	2.1	1 × 250	4	739	390	280	100	300	3/8"	3/8"
HCBS-1/3	3 × 10	1.57	1.58	2.54	2.9	1 × 250	4	578	375	280	120	300	3/8"	3/8"
HCBS-1/2	4 × 10	1.61	1.62	2.54	3.8	1 × 250	4	497	380	280	140	290	3/8"	3/8"
HCBS-3/4	4 × 12	3.02	3.04	2.54	5.4	1 × 300	4	1001	445	370	150	350	3/8"	3/8"
HCBS-1	4 × 14	3.71	3.75	2.54	7.3	1 × 300	4	1189	490	370	192	400	1/2"	3/8"
HCBS-1.5	4 × 16	6.24	6.30	2.54	10.4	1 × 350	4	2147	590	420	192	500	1/2"	3/8"
HCBS-2	4 × 18	9.09	9.18	2.1	14.0	1 × 400	4	2911	690	470	192	600	1/2"	3/8"
HCBS-2.5	5 × 18	9.65	9.73	2.1	17.5	1 × 400	4	2719	710	470	233	600	5/8"	1/2"
HCBS-3	6 × 18	9.87	9.95	2.1	21.0	1 × 400	4	2513	710	470	255	600	5/8"	1/2"
HCBS-4	6 × 22	14.43	14.57	2.1	25.7	1 × 450	4	3893	710	570	255	600	5/8"	1/2"
HCBS-5	4 × 30	22.15	22.37	2.1	34.5	1 × 500	4	7451	910	780	233	800	5/8"	1/2"
HCBS-6	4 × 32	23.03	23.23	2.83	47.3	1 × 500	4	8344	1090	830	233	980	3/4"	5/8"
HCBS-7	4 × 36	36.16	36.53	2.83	54.3	1 × 630	4	15524	1118	930	238	1000	7/8"	3/4"
HCBS-7	4 × 36	23.85	24.05	2.83	54.3	1 × 630	6	8228	1118	930	238	1000	7/8"	3/4"
HCBS-8	4 × 42	31.50	31.81	2.83	63.4	1 × 710	6	11868	1124	1080	334	1000	1-1/8"	7/8"
HCBS-9	5 × 42	33.51	33.79	2.83	71.3	1 × 710	6	11013	1124	1080	356	900	1-1/8"	7/8"
HCBS-10	4 × 48	44.52	44.92	2.83	77.5	1 × 800	6	17449	1194	1230	334	1070	1-1/8"	7/8"
HCBS-1CD	4 × 10	2.21	2.23	2.1	6.5	2 × 200	4	567	590	270	192	500	3/8"	3/8"
HCBS-1.5CD	4 × 11	4.06	4.10	2.1	9.4	2 × 250	4	1124	730	305	192	660	1/2"	3/8"
HCBS-2CD	4 × 12	6.94	7.00	2.1	12.4	2 × 300	4	2111	895	370	192	800	1/2"	3/8"
HCBS-3CD	4 × 16	13.24	13.36	2.1	23.0	2 × 350	4	4166	1090	420	212	1000	5/8"	1/2"
HCBS-4CD	4 × 20	15.17	15.30	2.1	28.7	2 × 350	4	4608	1110	525	212	1000	5/8"	1/2"
HCBS-5CD	4 × 24	19.58	19.75	2.1	34.5	2 × 400	4	6123	1110	625	233	1000	5/8"	1/2"
HCBS-6CD	4 × 26	22.76	22.95	2.1	44.8	2 × 400	4	6763	1310	670	233	1200	5/8"	1/2"
HCBS-7.5CD	4 × 32	33.78	34.08	2.1	55.2	2 × 450	4	10980	1310	830	233	1200	7/8"	5/8"
HCBS-10CD	4 × 32	46.02	46.47	2.1	73.6	2 × 500	4	15266	1765	830	233	1600	1-1/8"	7/8"
HCBS-12CD	4 × 36	70.03	70.81	2.1	82.8	2 × 630	4	27116	1765	928	238	1600	1-1/8"	7/8"
HCBS-12CD	4 × 36	44.91	45.32	2.1	82.8	2 × 630	6	14039	1765	928	238	1600	1-1/8"	7/8"
HCBS-15CD	4 × 36	76.24	77.09	2.1	93.1	2 × 630	4	28618	1965	928	238	1800	1-1/8"	7/8"
HCBS-15CD	4 × 36	49.64	50.07	2.1	93.1	2 × 630	6	15229	1965	928	238	1800	1-1/8"	7/8"
HCBS-18CD	4 × 36	67.05	67.66	2.1	113.1	3 × 500	4	22258	2145	928	238	1980	1-1/8"	7/8"
HCBS-20CD	4 × 42	72.31	72.96	2.1	123.4	2 × 710	6	23071	2175	1078	334	2000	1-3/8"	1-1/8"
HCBS-25CD	4 × 42	76.15	76.78	2.1	132.8	2 × 710	6	23724	2375	1078	334	2200	1-3/8"	1-1/8"
HCBS-30CD	5 × 48	109.33	110.21	2.1	264.4	2 × 800	6	31838	2405	1230	350	2200	1-5/8"	1-3/8"
HCBS-12FD	3 × 56	48.67	49.26	2.54	84.2	4 × 450	4	22610	1355	1410	400	1200	1-1/8"	7/8"
HCBS-15FD	4 × 56	58.83	59.38	2.54	112.3	4 × 450	4	21350	1355	1410	400	1200	1-1/8"	7/8"
HCBS-40FD	4 × 84	144.62	145.92	2.1	336.5	4 × 710	6	46142	2178	2128	334	2000	1-5/8"	1-3/8"
HCBS-50FD	4 × 84	152.31	153.57	2.1	370.2	4 × 710	6	47448	2378	2128	334	2200	2-1/8"	1-5/8"
HCBS-60FD	5 × 96	218.65	220.43	2.1	528.9	4 × 800	6	63676	2414	2430	350	2200	2-1/8"	1-5/8"

# 选配



## 铜管

- $\varnothing 9.52$  mm 内螺纹铜管
- $\varnothing 7$  mm 内螺纹铜管



## 钣金

- 按客户需求喷涂

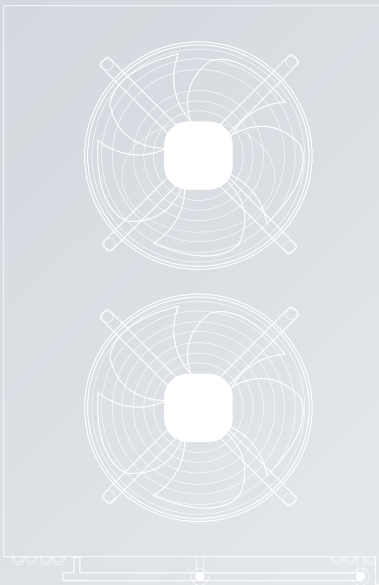
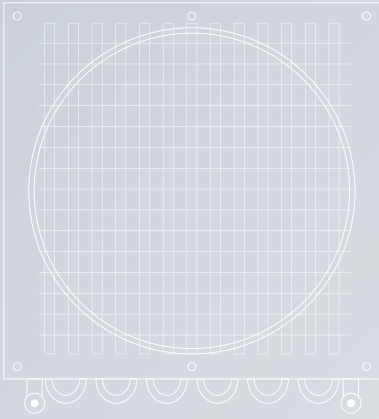
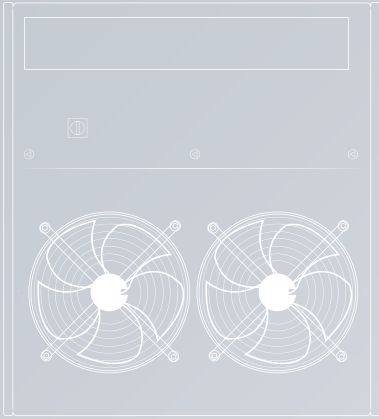
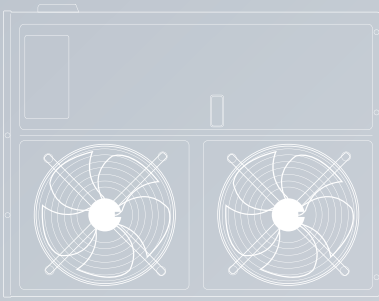



# HCV 冷凝器

## HCV 冷凝器

HCV 的高效内芯采用铝箔和  $\phi 9.52\text{mm}$  内螺纹铜管。所有内芯均经过清洁和 30bar 保压测试。

外壳采用“悬浮”结构，以避免铜管和侧板板之间产生接触，确保冷凝器的使用寿命长且无泄漏。

在室外设备上，蓝色翅片有助于保护部件免受腐蚀。

01 白色喷涂的镀锌板外壳，有较高的防腐蚀和抗震性能。

02 可使用“Unit Selector Hybrid HISPANIA”选型软件查询样册以外的工况性能。



更多需求和信息请联系 Hispania。

# HCV 6303-309-4D

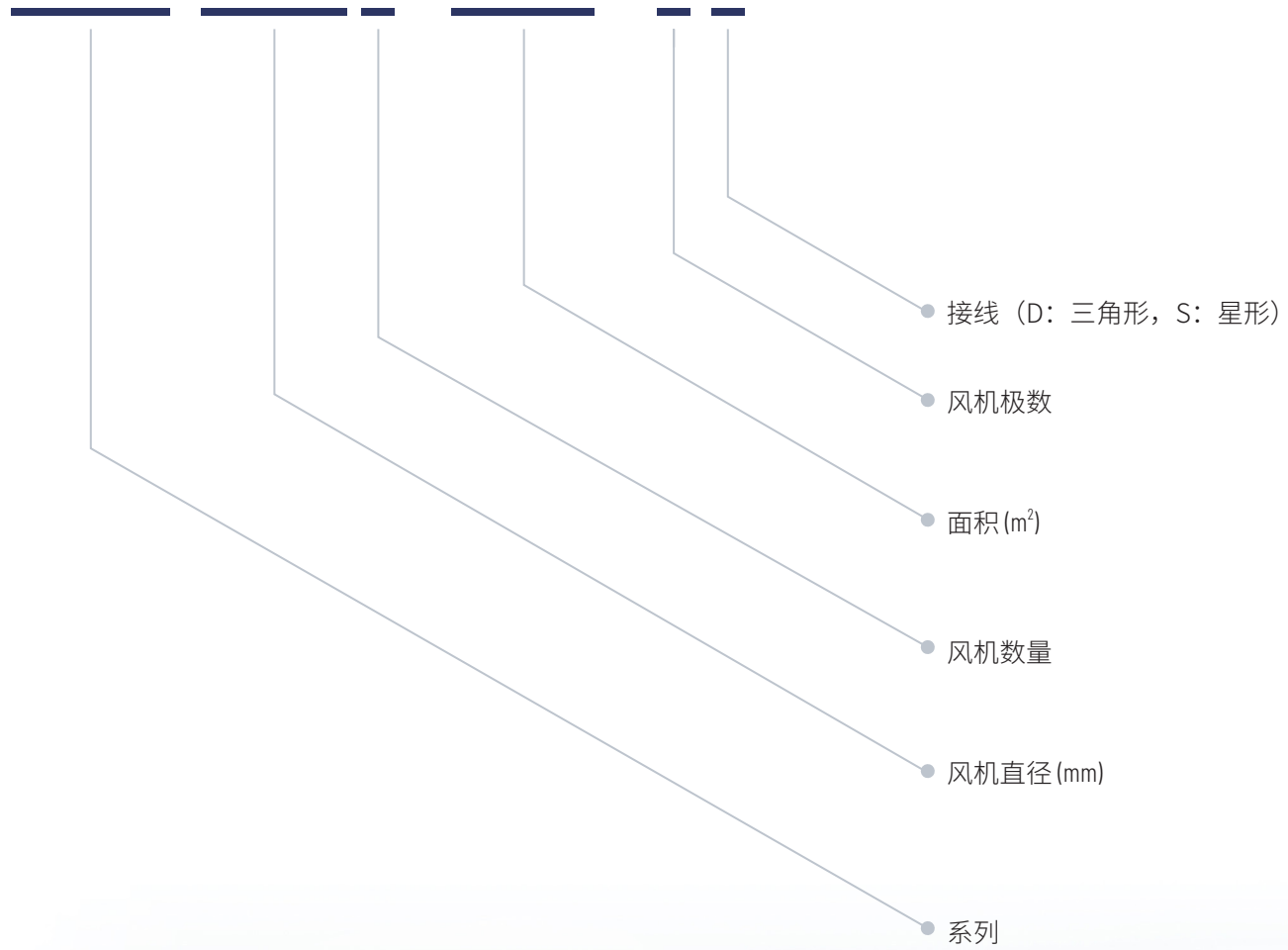

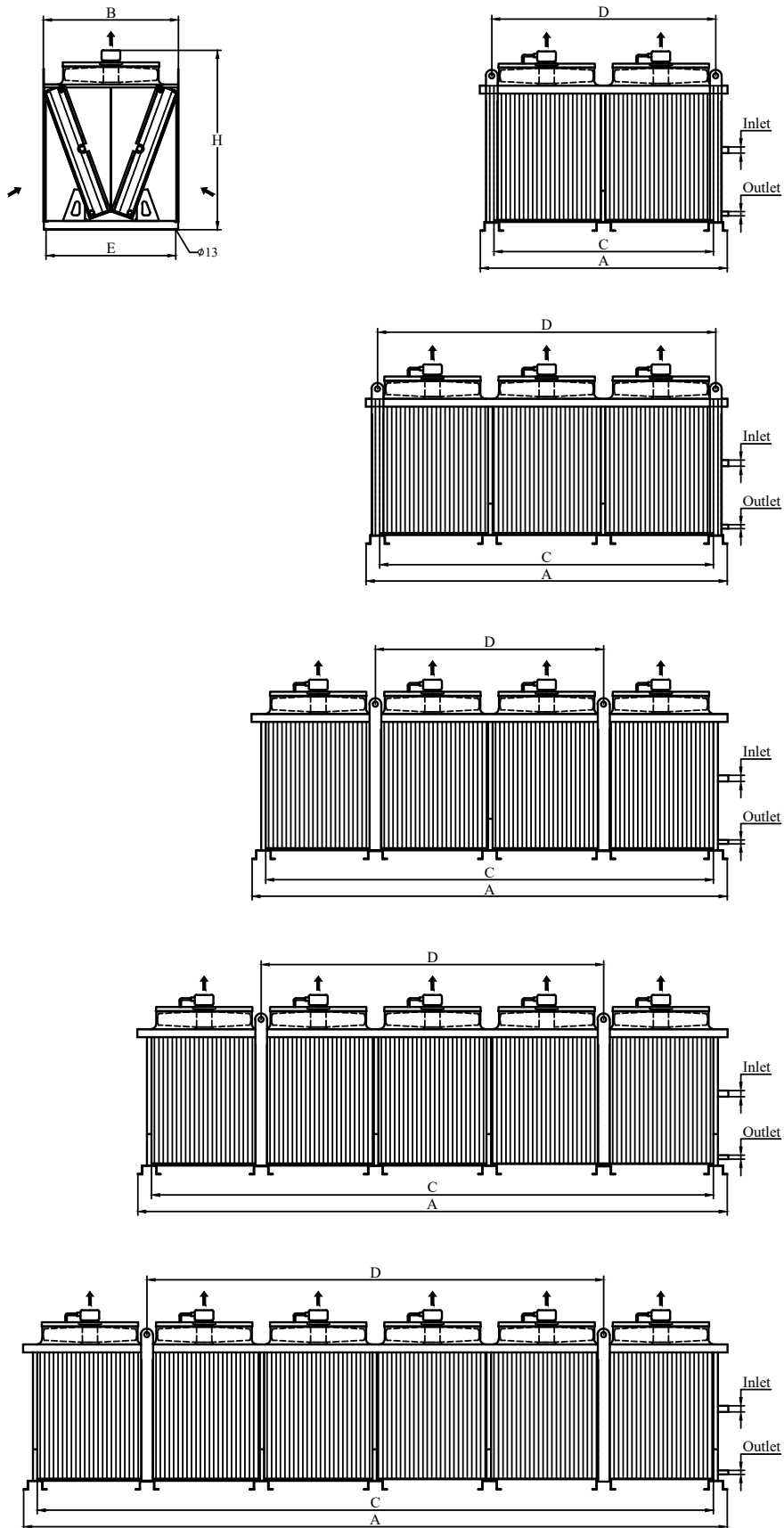

型号	外形尺寸(mm)					
	A	B	C	D	E	H
HCV 5002...	1446	781	1320	1350	720	859
HCV 5003...	2121	781	1995	2025	720	859
HCV 5004...	2796	781	2670	2700	720	859
HCV 5005...	3471	781	3345	3375	720	859
HCV 5006...	4146	781	4020	4050	720	859
HCV 6302...	1694	912	1500	1540	865	1210
HCV 6303...	2464	912	2270	2310	865	1210
HCV 6304...	3234	912	3040	1540	865	1210
HCV 6305...	4004	912	3810	2310	865	1210
HCV 6306...	4774	912	4580	3080	865	1210
HCV 8002...	2256	1150	2070	2100	1113	1435
HCV 8003...	3306	1150	3120	3150	1113	1435
HCV 8004...	4356	1150	4170	2100	1113	1435
HCV 8005...	5406	1150	5220	3150	1113	1435
HCV 8006...	6456	1150	6270	4200	1113	1435
*HCV 8002...	2256	1195	2070	2100	1158	1470
*HCV 8003...	3306	1195	3120	3150	1158	1470
*HCV 8004...	4356	1195	4170	2100	1158	1470
*HCV 8005...	5406	1195	5220	3150	1158	1470
*HCV 8006...	6456	1195	6270	4200	1158	1470

带\*型号尺寸

型号	制冷量 (kW)		噪音	片距 (mm)	面积 (m <sup>2</sup> )	管容积 (dm <sup>3</sup> )	风机					接口尺寸 (mm)		净重 (kg)
	R404A/ R507A	R448A / R449A	距离 =10m				N° × Ø (mm)	极数/接线	功率 (W)	电流 (A)	风量 (m <sup>3</sup> /h)	进	出	
	DT1=15K	DT1=15K	dBA											
HCV 5002 121-4D	51.32	51.71	54	2.1	121	16	2 × 500	4P-Δ	1300	2.4	14583	2×28	2×22	161
HCV 5002 151-4D	55.18	55.51	54	2.1	151.3	20	2 × 500	4P-Δ	1300	2.4	14168	2×28	2×22	161
HCV 5003 182-4D	77.27	77.83	55	2.1	182.9	24.2	3 × 500	4P-Δ	1950	3.6	21889	2×28	2×22	233
HCV 5003 227-4D	83.08	83.57	55	2.1	228.7	30.2	3 × 500	4P-Δ	1950	3.6	21283	2×28	2×22	233
HCV 5004 242-4D	102.29	103.27	60	2.1	244.8	32.3	4 × 500	4P-Δ	2600	4.8	29209	2×35	2×28	304
HCV 5004 303-4D	110.35	111.2	60	2.1	306	40.4	4 × 500	4P-Δ	2600	4.8	28399	2×35	2×28	304
HCV 5005 303-4D	128.62	129.71	62	2.1	306.7	40.5	5 × 500	4P-Δ	3250	6.0	36529	2×35	2×28	374
HCV 5005 378-4D	138.53	139.51	62	2.1	383.4	50.6	5 × 500	4P-Δ	3250	6.0	35514	2×35	2×28	374
HCV 5006 363-4D	155.21	156.32	65	2.1	368.6	48.7	6 × 500	4P-Δ	3900	7.2	43849	2×35	2×28	445
HCV 5006 454-4D	166.38	167.55	65	2.1	460.8	60.8	6 × 500	4P-Δ	3900	7.2	42630	2×35	2×28	445

型号	制冷量 (kW)		噪音	片距 (mm)	面积 (m <sup>2</sup> )	管容积 (dm <sup>3</sup> )	风机					接口尺寸 (mm)		净重 (kg)
	R404A/ R507A	R448A / R449A	距离 =10m				N° × Ø (mm)	极数/接线	功率 (W)	电流 (A)	风量 (m <sup>3</sup> /h)	进	出	
	DT1=15K	DT1=15K	dBA											
HCV 6302 206-4D	86.03	86.62	55	2.1	206.3	27.2	2 × 630	4P-Δ	2200	4.4	24362	2×28	2×22	242
HCV 6302 206-4S	70.06	70.5	52	2.1	206.3	27.2	2 × 630	4P-Y	1300	2.5	18712	2×28	2×22	242
HCV 6302 206-6D	76.69	77.2	48	2.1	206.3	27.2	2 × 630	6P-Δ	1452	3.5	20995	2×28	2×22	242
HCV 6302 206-6S	67.38	67.8	45	2.1	206.3	27.2	2 × 630	6P-Y	1114	1.9	17817	2×28	2×22	242
HCV 6302 258-4D	93.55	94.18	55	2.1	257.9	34	2 × 630	4P-Δ	2200	4.4	23954	2×28	2×22	261
HCV 6302 258-4S	74.55	74.95	52	2.1	257.9	34	2 × 630	4P-Y	1300	2.5	18144	2×28	2×22	261
HCV 6302 258-6D	82.15	82.6	48	2.1	257.9	34	2 × 630	6P-Δ	1452	3.5	20396	2×28	2×22	261
HCV 6302 258-6S	71.52	71.9	45	2.1	257.9	34	2 × 630	6P-Y	1114	1.9	17267	2×28	2×22	261
HCV 6302 310-4D	97.61	98.27	55	2.1	309.9	40.9	2 × 630	4P-Δ	2200	4.4	23471	2×28	2×22	280
HCV 6302 310-4S	76.92	77.31	52	2.1	309.9	40.9	2 × 630	4P-Y	1300	2.5	17716	2×28	2×22	280
HCV 6302 310-6D	84.93	85.37	48	2.1	309.9	40.9	2 × 630	6P-Δ	1452	3.5	19879	2×28	2×22	280
HCV 6302 310-6S	73.39	73.74	45	2.1	309.9	40.9	2 × 630	6P-Y	1114	1.9	16781	2×28	2×22	280
HCV 6303 309-4D	127.53	128.51	56	2.1	309.5	40.9	3 × 630	4P-Δ	3300	6.6	36543	2×35	2×22	349
HCV 6303 309-4S	103.91	104.63	53	2.1	309.5	40.9	3 × 630	4P-Y	1950	3.8	28068	2×35	2×22	349
HCV 6303 309-6D	113.76	114.58	49	2.1	309.5	40.9	3 × 630	6P-Δ	2178	5.2	31492	2×35	2×22	349
HCV 6303 309-6S	99.93	100.61	46	2.1	309.5	40.9	3 × 630	6P-Y	1671	2.9	26726	2×35	2×22	349
HCV 6303 387-4D	138.37	139.32	56	2.1	386.9	51.1	3 × 630	4P-Δ	3300	6.6	35930	2×35	2×22	377
HCV 6303 387-4S	110.15	110.82	53	2.1	386.9	51.1	3 × 630	4P-Y	1950	3.8	27216	2×35	2×22	377
HCV 6303 387-6D	121.4	122.18	49	2.1	386.9	51.1	3 × 630	6P-Δ	2178	5.2	30593	2×35	2×22	377
HCV 6303 387-6S	105.69	106.31	46	2.1	386.9	51.1	3 × 630	6P-Y	1671	2.9	25900	2×35	2×22	377
HCV 6303 468-4D	147.25	148.03	56	2.1	468.1	60.9	3 × 630	4P-Δ	3300	6.6	35262	2×35	2×22	405
HCV 6303 468-4S	115.79	116.31	53	2.1	468.1	60.9	3 × 630	4P-Y	1950	3.8	26617	2×35	2×22	405
HCV 6303 468-6D	127.94	128.59	49	2.1	468.1	60.9	3 × 630	6P-Δ	2178	5.2	29881	2×35	2×22	405
HCV 6303 468-6S	110.57	111.04	46	2.1	468.1	60.9	3 × 630	6P-Y	1671	2.9	25244	2×35	2×22	405
HCV 6304 415-4D	172.91	174.08	64	2.1	415.4	54.8	4 × 630	4P-Δ	4400	8.8	48754	2×42	2×28	456
HCV 6304 415-4S	140.91	141.77	61	2.1	415.4	54.8	4 × 630	4P-Y	2600	5	37479	2×42	2×28	456
HCV 6304 415-6D	154.26	155.26	57	2.1	415.4	54.8	4 × 630	6P-Δ	2904	7	42045	2×42	2×28	456
HCV 6304 415-6S	135.51	136.32	54	2.1	415.4	54.8	4 × 630	6P-Y	2228	3.9	35686	2×42	2×28	456
HCV 6304 519-4D	187.4	188.56	64	2.1	519.2	68.6	4 × 630	4P-Δ	4400	8.8	47964	2×42	2×28	493
HCV 6304 519-4S	149.16	149.94	61	2.1	519.2	68.6	4 × 630	4P-Y	2600	5	36343	2×42	2×28	493
HCV 6304 519-6D	164.43	165.35	57	2.1	519.2	68.6	4 × 630	6P-Δ	2904	7	40854	2×42	2×28	493
HCV 6304 519-6S	143.1	143.84	54	2.1	519.2	68.6	4 × 630	6P-Y	2228	3.9	34591	2×42	2×28	493
HCV 6304 627-4D	196.38	197.42	64	2.1	624.8	77.6	4 × 630	4P-Δ	4400	8.8	47053	2×42	2×28	530
HCV 6304 627-4S	154.41	155.1	61	2.1	624.8	77.6	4 × 630	4P-Y	2600	5	35518	2×42	2×28	530
HCV 6304 627-6D	170.65	171.49	57	2.1	624.8	77.6	4 × 630	6P-Δ	2904	7	39882	2×42	2×28	530
HCV 6304 627-6S	147.48	148.1	54	2.1	624.8	77.6	4 × 630	6P-Y	2228	3.9	33696	2×42	2×28	530

型号	制冷量 (kW)		噪音	片距 (mm)	面积 (m <sup>2</sup> )	管容积 (dm <sup>3</sup> )	风机					接口尺寸 (mm)		净重 (kg)
	R404A/ R507A	R448A / R449A	距离 =10m				N° × Ø (mm)	极数/接线	功率 (W)	电流 (A)	风量 (m <sup>3</sup> /h)	进	出	
	DT1=15K	DT1=15K	dBA											
HCV 6305 521-4D	217	218.65	65	2.1	521.3	68.8	5 × 630	4P-Δ	5500	11	60965	2×54	2×35	561
HCV 6305 521-4S	177.25	178.3	62	2.1	521.3	68.8	5 × 630	4P-Y	3250	6.3	46890	2×54	2×35	561
HCV 6305 521-6D	193.9	195.23	58	2.1	521.3	68.8	5 × 630	6P-Δ	3630	8.7	52598	2×54	2×35	561
HCV 6305 521-6S	170.5	171.47	55	2.1	521.3	68.8	5 × 630	6P-Y	2785	4.9	44646	2×54	2×35	561
HCV 6305 652-4D	235.4	236.93	65	2.1	651.6	86	5 × 630	4P-Δ	5500	11	59997	2×54	2×35	607
HCV 6305 652-4S	187.56	188.54	62	2.1	651.6	86	5 × 630	4P-Y	3250	6.3	45469	2×54	2×35	607
HCV 6305 652-6D	206.75	207.85	58	2.1	651.6	86	5 × 630	6P-Δ	3630	8.7	51115	2×54	2×35	607
HCV 6305 652-6S	179.98	180.89	55	2.1	651.6	86	5 × 630	6P-Y	2785	4.9	43282	2×54	2×35	607
HCV 6305 786-4D	244.04	245.38	65	2.1	778.2	87.5	5 × 630	4P-Δ	5500	11	58844	2×54	2×35	653
HCV 6305 786-4S	191.81	192.68	62	2.1	778.2	87.5	5 × 630	4P-Y	3250	6.3	44418	2×54	2×35	653
HCV 6305 786-6D	212.06	213.1	58	2.1	778.2	87.5	5 × 630	6P-Δ	3630	8.7	49883	2×54	2×35	653
HCV 6305 786-6S	183.21	184.01	55	2.1	778.2	87.5	5 × 630	6P-Y	2785	4.9	42147	2×54	2×35	653
HCV 6306 627-4D	255.89	257.84	66	2.1	627.2	82.8	6 × 630	4P-Δ	6600	13.2	73176	2×54	2×35	667
HCV 6306 627-4S	208.59	210.01	63	2.1	627.2	82.8	6 × 630	4P-Y	3900	7.5	56300	2×54	2×35	667
HCV 6306 627-6D	228.36	229.99	59	2.1	627.2	82.8	6 × 630	6P-Δ	4356	10.4	63151	2×54	2×35	667
HCV 6306 627-6S	200.59	201.93	56	2.1	627.2	82.8	6 × 630	6P-Y	3342	5.8	53606	2×54	2×35	667
HCV 6306 784-4D	281.68	283.81	66	2.1	784	103.5	6 × 630	4P-Δ	6600	13.2	72029	2×54	2×35	722
HCV 6306 784-4S	225.15	226.35	63	2.1	784	103.5	6 × 630	4P-Y	3900	7.5	54596	2×54	2×35	722
HCV 6306 784-6D	247.85	249.47	59	2.1	784	103.5	6 × 630	6P-Δ	4356	10.4	61376	2×54	2×35	722
HCV 6306 784-6S	216.13	217.24	56	2.1	784	103.5	6 × 630	6P-Y	3342	5.8	51973	2×54	2×35	722
HCV 6306 945-4D	294.08	295.63	66	2.1	935.2	105.2	6 × 630	4P-Δ	6600	13.2	70635	2×54	2×35	777
HCV 6306 945-4S	231.22	232.26	63	2.1	935.2	105.2	6 × 630	4P-Y	3900	7.5	53319	2×54	2×35	777
HCV 6306 945-6D	255.6	256.85	59	2.1	935.2	105.2	6 × 630	6P-Δ	4356	10.4	59883	2×54	2×35	777
HCV 6306 945-6S	220.9	221.85	56	2.1	935.2	105.2	6 × 630	6P-Y	3342	5.8	50599	2×54	2×35	777

型号	制冷量 (kW)		噪音	片距 (mm)	面积 (m <sup>2</sup> )	管容积 (dm <sup>3</sup> )	风机					接口尺寸 (mm)		净重 (kg)
	R404A/ R507A	R448A / R449A	距离 =10m				N° × Ø (mm)	极数/ 接线	功率 (W)	电流 (A)	风量 (m <sup>3</sup> /h)	进	出	
	DT1=15K	DT1=15K	dBA											
HCV 8002 358-6D	140.54	141.64	51	2.1	332.2	43.9	2 × 800	6P-Δ	3200	7	39845	2×42	2×28	358
HCV 8002 358-6S	108.67	109.3	42	2.1	332.2	43.9	2 × 800	6P-Y	1600	3.1	28571	2×42	2×28	358
HCV 8002 448-6D	150.75	151.99	51	2.1	415.2	54.8	2 × 800	6P-Δ	3200	7	38857	2×42	2×28	387
HCV 8002 448-6S	114.84	115.45	42	2.1	415.2	54.8	2 × 800	6P-Y	1600	3.1	27735	2×42	2×28	387
*HCV 8002 498-6D	155.62	157.01	51	2.1	498.3	65.8	2 × 800	6P-Δ	3200	7	37859	2×42	2×28	416
*HCV 8002 498-6S	117.38	118	42	2.1	498.3	65.8	2 × 800	6P-Y	1600	3.1	26972	2×42	2×28	416
HCV 8003 538-6D	210.92	212.72	53	2.1	500.7	66.1	3 × 800	6P-Δ	4800	10.5	59816	2×54	2×35	520
HCV 8003 538-6S	163.44	164.49	44	2.1	500.7	66.1	3 × 800	6P-Y	2400	4.7	42899	2×54	2×35	520
HCV 8003 673-6D	227.63	229.25	53	2.1	625.8	82.6	3 × 800	6P-Δ	4800	10.5	58347	2×54	2×35	564
HCV 8003 673-6S	172.9	173.74	44	2.1	625.8	82.6	3 × 800	6P-Y	2400	4.7	41650	2×54	2×35	564
*HCV 8003 751-6D	237.31	238.72	53	2.1	751	99.1	3 × 800	6P-Δ	4800	10.5	56859	2×54	2×35	594
*HCV 8003 751-6S	177.53	178.3	44	2.1	751	99.1	3 × 800	6P-Y	2400	4.7	40511	2×54	2×35	594
HCV 8004 721-6D	282.23	284.38	54	2.1	669.2	88.3	4 × 800	6P-Δ	6400	14	79787	2×54	2×35	677
HCV 8004 721-6S	218.15	219.37	45	2.1	669.2	88.3	4 × 800	6P-Y	3200	6.2	57226	2×54	2×35	677
HCV 8004 901-6D	298.86	301.99	54	2.1	836.5	110.4	4 × 800	6P-Δ	6400	14	77838	2×54	2×35	736
HCV 8004 901-6S	228.96	230.62	45	2.1	836.5	110.4	4 × 800	6P-Y	3200	6.2	55566	2×54	2×35	736
*HCV 8004 1004-6D	316.95	318.55	54	2.1	1003.7	132.5	4 × 800	6P-Δ	6400	14	75859	2×54	2×35	766
*HCV 8004 1004-6S	236.79	237.76	45	2.1	1003.7	132.5	4 × 800	6P-Y	3200	6.2	54050	2×54	2×35	766

型号	制冷量 (kW)		噪音	片距 (mm)	面积 (m <sup>2</sup> )	管容积 (dm <sup>3</sup> )	风机					接口尺寸 (mm)		净重 (kg)
	R404A/ R507A	R448A / R449A	距离 =10m				N° × Ø (mm)	极数/接线	功率 (W)	电流 (A)	风量 (m <sup>3</sup> /h)	进	出	
	DT1=15K	DT1=15K	dBA											
HCV 8005 902-6D	350.68	354.01	55	2.1	837.7	110.6	5 × 800	6P-Δ	8000	17.5	99759	2×67	2×42	834
HCV 8005 902-6S	272.44	274.36	46	2.1	837.7	110.6	5 × 800	6P-Y	4000	7.8	71554	2×67	2×42	834
HCV 8005 1128-6D	378.94	381.93	55	2.1	1047.1	138.2	5 × 800	6P-Δ	8000	17.5	97328	2×67	2×42	908
HCV 8005 1128-6S	288.42	289.92	46	2.1	1047.1	138.2	5 × 800	6P-Y	4000	7.8	69481	2×67	2×42	908
*HCV 8005 1257-6D	395.38	397.96	55	2.1	1256.5	165.9	5 × 800	6P-Δ	8000	17.5	94859	2×67	2×42	938
*HCV 8005 1257-6S	296.23	297.59	46	2.1	1256.5	165.9	5 × 800	6P-Y	4000	7.8	67589	2×67	2×42	938
HCV 8006 1084-6D	413.99	419.14	56	2.1	1006.2	132.8	6 × 800	6P-Δ	9600	21	119730	2×67	2×42	992
HCV 8006 1084-6S	324.05	326.96	47	2.1	1006.2	132.8	6 × 800	6P-Y	4800	9.3	85882	2×67	2×42	992
HCV 8006 1355-6D	449.11	453.75	56	2.1	1257.7	166	6 × 800	6P-Δ	9600	21	116818	2×67	2×42	1081
HCV 8006 1355-6S	343.95	346.41	47	2.1	1257.7	166	6 × 800	6P-Y	4800	9.3	83396	2×67	2×42	1081
*HCV 8006 1509-6D	469.97	473.95	56	2.1	1509.2	199.3	6 × 800	6P-Δ	9600	21	113858	2×67	2×42	1111
*HCV 8006 1509-6S	354.05	355.85	47	2.1	1509.2	199.3	6 × 800	6P-Y	4800	9.3	81128	2×67	2×42	1111

# 选配



钣金  
• 按客户需求喷涂

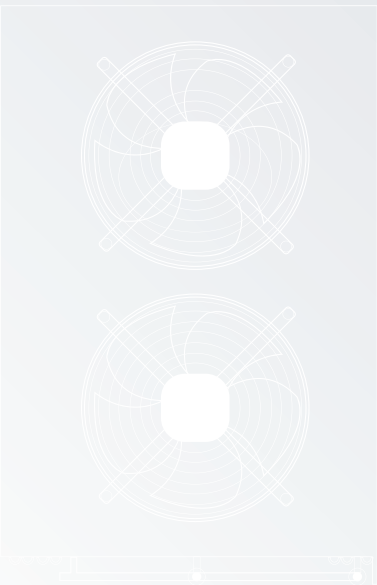
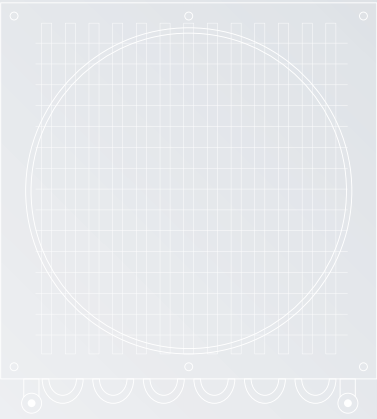
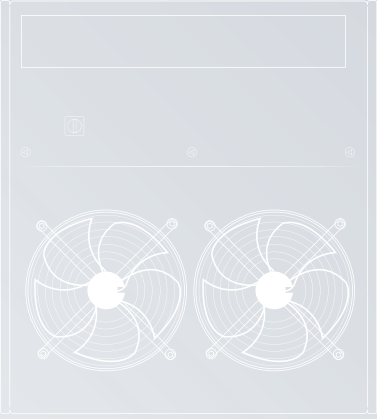
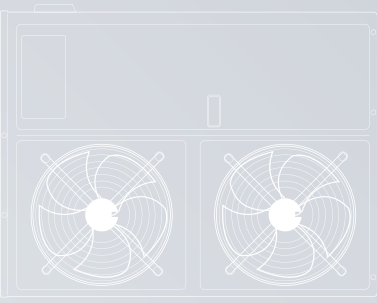



# HCVD 冷凝器

HCVD 的高效内芯采用铝箔和  $\varnothing 9.52\text{mm}$  内螺纹铜管。所有内芯均经过清洁和 30bar 保压测试。  
外壳采用“悬浮”结构，以避免铜管和侧板板之间产生接触，确保冷凝器的使用寿命长且无泄漏。  
在室外设备上，蓝色翅片有助于保护部件免受腐蚀。

- 01 白色喷涂的镀锌板外壳，有较高的防腐蚀和抗震性能。
- 02 可使用“Unit Selector Hybrid HISPANIA”选型软件查询样册以外的工况性能。

 更多需求和信息请联系 Hispania。



# HCVD 8006 1049-6D

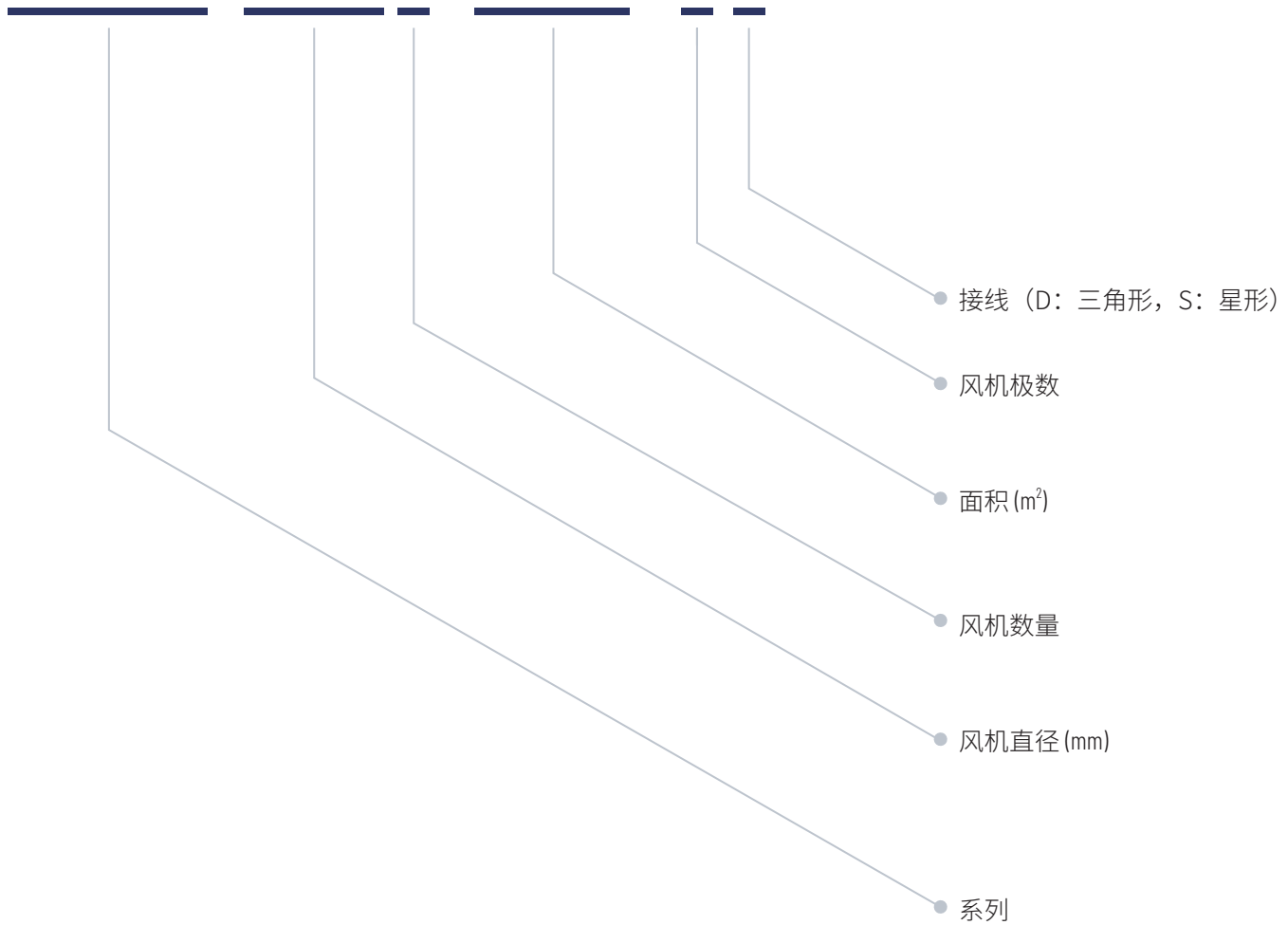



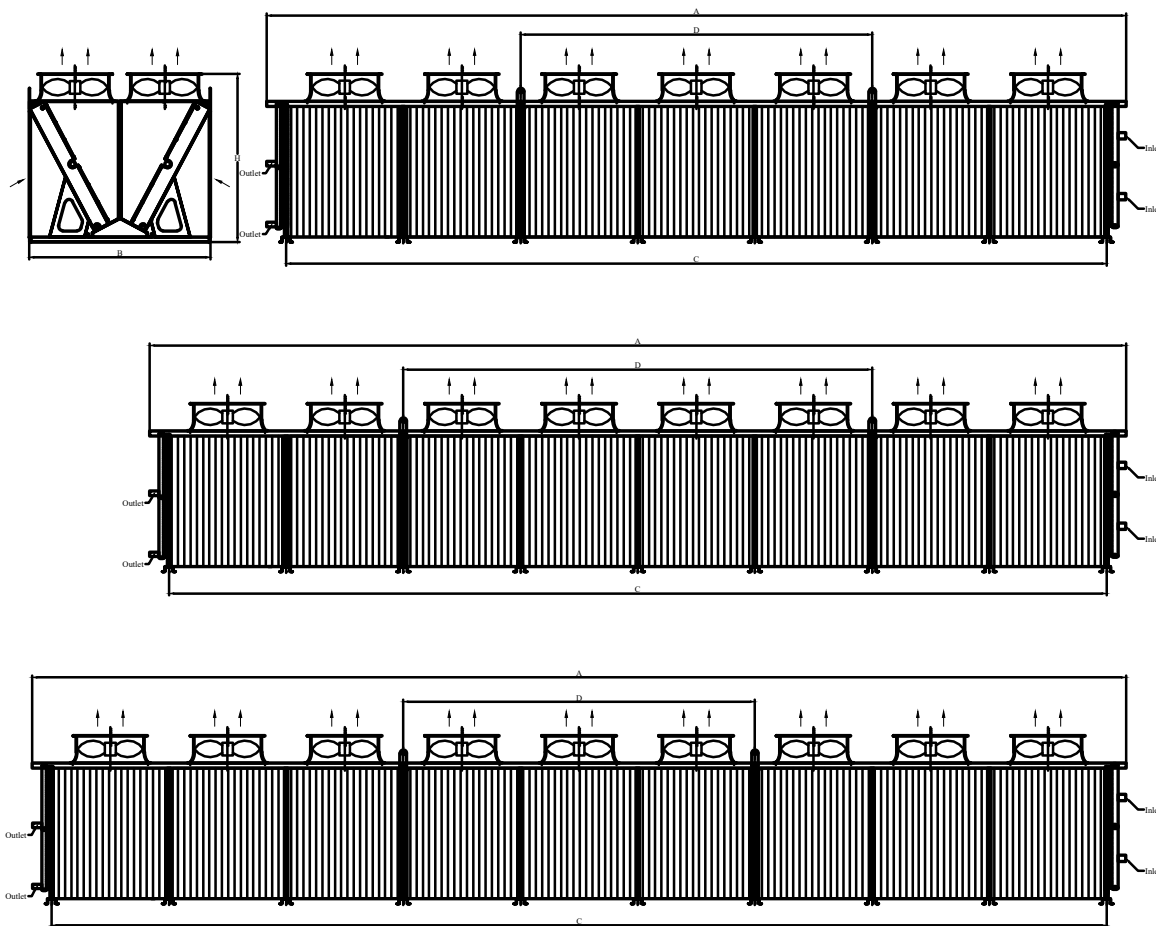

型号	外形尺寸(mm)				
	A	B	C	D	H
HCVD 8004...	3100	2160	2800	2800	2010
HCVD 8006...	4500	2160	4200	4200	2010
HCVD 8008...	5930	2160	5600	2800	2010
HCVD 8010...	7330	2160	7000	4200	2010
HCVD 8012...	8730	2160	8400	5600	2010
HCVD 8014...	10265	2160	9800	4200	2010
HCVD 8016...	11665	2160	11200	5600	2010
HCVD 8018...	13065	2160	12600	4200	2010

型号	制冷量 (kW)		噪音	片距 (mm)	面积 (m <sup>2</sup> )	管容积 (dm <sup>3</sup> )	风机					接口尺寸 (mm)		净重 (kg)
	R404A/ R507A	R448A / R449A	距离 =10m				N° × Ø (mm)	极数/接线	功率 (W)	电流 (A)	风量 (m <sup>3</sup> /h)	进	出	
	DT1=15K	DT1=15K	dBA											
HCVD 8004 696-6D	282.42	284.5	44	2.1	696	92	4 × 800	6P-Δ	6400	14	80308	2×67	2×54	934
HCVD 8004 696-6S	217.75	219.14	35	2.1	696	92	4 × 800	6P-Y	3200	6.2	58042	2×67	2×54	934
HCVD 8004 870-6D	304.32	306.3	44	2.1	870	114	4 × 800	6P-Δ	6400	14	78466	2×67	2×54	1333
HCVD 8004 870-6S	230.42	231.68	35	2.1	870	114	4 × 800	6P-Y	3200	6.2	56210	2×67	2×54	1333
HCVD 8004 1044-6D	317.35	319.17	44	2.1	1044	138	4 × 800	6P-Δ	6400	14	76609	4×67	4×54	1736
HCVD 8004 1044-6S	237	238.12	35	2.1	1044	138	4 × 800	6P-Y	3200	6.2	54550	4×67	4×54	1736
HCVD 8006 1049-6D	430.29	433.47	44	2.1	1049	139	6 × 800	6P-Δ	9600	21	120553	4×67	4×54	2130
HCVD 8006 1049-6S	332.45	334.29	35	2.1	1049	139	6 × 800	6P-Y	4800	9.3	87157	4×67	4×54	2130
HCVD 8006 1311-6D	463.54	466.47	44	2.1	1311	172	6 × 800	6P-Δ	9600	21	117806	4×67	4×54	2524
HCVD 8006 1311-6S	351.21	352.94	35	2.1	1311	172	6 × 800	6P-Y	4800	9.3	84421	4×67	4×54	2524
HCVD 8006 1574-6D	483.17	485.58	44	2.1	1574	208	6 × 800	6P-Δ	9600	21	115049	4×76	4×54	2938
HCVD 8006 1574-6S	360.73	362.2	35	2.1	1574	208	6 × 800	6P-Y	4800	9.3	81941	4×76	4×54	2938
HCVD 8008 1402-6D	566.71	570.84	44	2.1	1402	185	8 × 800	6P-Δ	12800	28	160799	4×76	4×54	3332
HCVD 8008 1402-6S	436.89	439.66	35	2.1	1402	185	8 × 800	6P-Y	6400	12.4	116272	4×76	4×54	3332
HCVD 8008 1753-6D	610.62	614.55	44	2.1	1753	231	8 × 800	6P-Δ	12800	28	157146	4×76	4×54	3726
HCVD 8008 1753-6S	462.26	464.79	35	2.1	1753	231	8 × 800	6P-Y	6400	12.4	112631	4×76	4×54	3726
HCVD 8008 2103-6D	636.73	640.33	44	2.1	2103	278	8 × 800	6P-Δ	12800	28	153488	2×67	2×54	999
HCVD 8008 2103-6S	475.41	477.64	35	2.1	2103	278	8 × 800	6P-Y	6400	12.4	109331	2×67	2×54	999
HCVD 80010 1755-6D	716.41	721.13	44	2.1	1755	232	10 × 800	6P-Δ	16000	35	201044	2×67	2×54	1429
HCVD 80010 1755-6S	552.34	555.54	35	2.1	1755	232	10 × 800	6P-Y	8000	15.5	145386	2×67	2×54	1429
HCVD 80010 2194-6D	771.25	775.9	44	2.1	2194	290	10 × 800	6P-Δ	16000	35	196485	4×67	4×54	1864
HCVD 80010 2194-6S	583.83	586.7	35	2.1	2194	290	10 × 800	6P-Y	8000	15.5	140841	4×67	4×54	1864
HCVD 80010 2633-6D	803.65	807.84	44	2.1	2633	348	10 × 800	6P-Δ	16000	35	191926	4×67	4×54	2289
HCVD 80010 2633-6S	599.73	602.22	35	2.1	2633	348	10 × 800	6P-Y	8000	15.5	136721	4×67	4×54	2289

型号	制冷量 (kW)		噪音	片距 (mm)	面积 (m <sup>2</sup> )	管容积 (dm <sup>3</sup> )	风机					接口尺寸 (mm)		净重 (kg)
	R404A/ R507A	R448A / R449A	距离 =10m				N° × Ø (mm)	极数/接线	功率 (W)	电流 (A)	风量 (m <sup>3</sup> /h)	进	出	
	DT1=15K	DT1=15K	dBA											
HCVD 80012 2108-6D	862.65	868.94	44	2.1	2108	278	12 × 800	6P-Δ	19200	42	241289	4×67	4×54	2715
HCVD 80012 2108-6S	666.36	670.02	35	2.1	2108	278	12 × 800	6P-Y	9600	18.6	174501	4×67	4×54	2715
HCVD 80012 2635-6D	929.36	934.77	44	2.1	2635	348	12 × 800	6P-Δ	19200	42	235825	4×76	4×67	3167
HCVD 80012 2635-6S	703.99	707.42	35	2.1	2635	348	12 × 800	6P-Y	9600	18.6	169051	4×76	4×67	3167
HCVD 80012 3162-6D	968.46	973.24	44	2.1	3162	418	12 × 800	6P-Δ	19200	42	230365	4×76	4×67	3592
HCVD 80012 3162-6S	722.9	725.82	35	2.1	3162	418	12 × 800	6P-Y	9600	18.6	164111	4×76	4×67	3592
HCVD 80014 2461-6D	984.11	991.75	44	2.1	2461	325	14 × 800	6P-Δ	22400	49	281534	4×76	4×67	4018
HCVD 80014 2461-6S	758.93	764.12	35	2.1	2461	325	14 × 800	6P-Y	11200	21.7	203615	4×76	4×67	4018
HCVD 80014 3077-6D	1061.02	1068.37	44	2.1	3077	406	14 × 800	6P-Δ	22400	49	275164	2×67	2×54	1062
HCVD 80014 3077-6S	803.73	808.5	35	2.1	3077	406	14 × 800	6P-Y	11200	21.7	197261	2×67	2×54	1062
HCVD 80014 3692-6D	1107.27	1114.03	44	2.1	3692	487	14 × 800	6P-Δ	22400	49	268803	2×67	2×54	1524
HCVD 80014 3692-6S	827.33	831.58	35	2.1	3692	487	14 × 800	6P-Y	11200	21.7	191501	2×67	2×54	1524
HCVD 80016 2814-6D	1135.29	1143.51	44	2.1	2814	372	16 × 800	6P-Δ	25600	56	321779	4×67	4×54	1992
HCVD 80016 2814-6S	875.17	880.68	35	2.1	2814	372	16 × 800	6P-Y	12800	24.8	232729	4×67	4×54	1992
HCVD 80016 3518-6D	1223.15	1230.97	44	2.1	3518	464	16 × 800	6P-Δ	25600	56	314504	4×76	4×54	2453
HCVD 80016 3518-6S	925.93	930.97	35	2.1	3518	464	16 × 800	6P-Y	12800	24.8	225471	4×76	4×54	2453
HCVD 80016 4221-6D	1275.47	1282.62	44	2.1	4221	557	16 × 800	6P-Δ	25600	56	307242	4×76	4×54	2910
HCVD 80016 4221-6S	952.23	956.66	35	2.1	4221	557	16 × 800	6P-Y	12800	24.8	218891	4×76	4×54	2910
HCVD 80018 3167-6D	1285.79	1294.42	44	2.1	3167	418	18 × 800	6P-Δ	28800	63	362024	4×89	4×76	3399
HCVD 80018 3167-6S	990.95	996.82	35	2.1	3167	418	18 × 800	6P-Y	14400	27.9	261844	4×89	4×76	3399
HCVD 80018 3959-6D	1384.39	1392.82	44	2.1	3959	523	18 × 800	6P-Δ	28800	63	353843	4×89	4×76	3856
HCVD 80018 3959-6S	1047.76	1053.1	35	2.1	3959	523	18 × 800	6P-Y	14400	27.9	253681	4×89	4×76	3856
HCVD 80018 4751-6D	1442.88	1450.57	44	2.1	4751	627	18 × 800	6P-Δ	28800	63	345680	4×89	4×76	4312
HCVD 80018 4751-6S	1076.78	1081.43	35	2.1	4751	627	18 × 800	6P-Y	14400	27.9	246281	4×89	4×76	4312

# 选配



钣金  
• 按客户需求喷涂

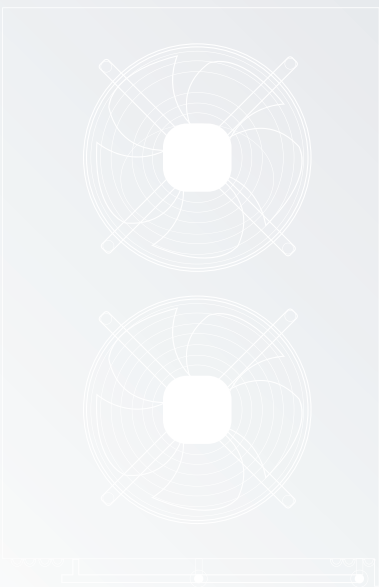
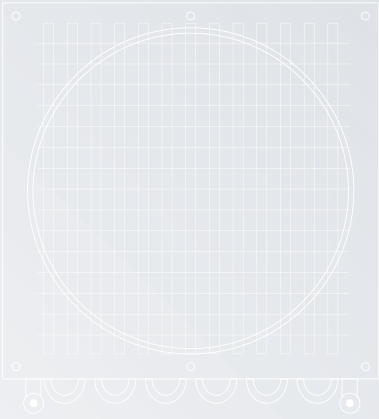
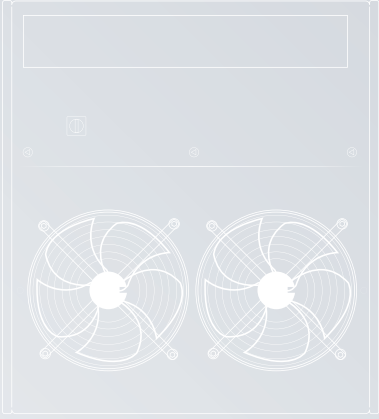
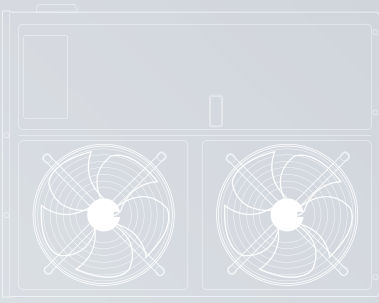

# 业务范围



- 中国
- 智利
- 以色列
- 西班牙
- 哥伦比亚
- 澳大利亚
- 墨西哥
- 泰国
- 英国
- 北马其顿
- 新西兰
- 阿尔及利亚
- 乌克兰
- 马来西亚
- 波兰
- 秘鲁
- 乌拉圭
- 俄罗斯
- 匈牙利
- 巴拿马
- 保加利亚
- 印度
- 厄瓜多尔
- 美国
- 也门
- 法国
- 马耳他
- 沙特阿拉伯
- 加蓬
- 萨尔瓦多
- 黎巴嫩
- 土耳其
- 多米尼加
- 阿根廷
- 叙利亚
- 意大利
- 委内瑞拉
- 新加坡
- 马达加斯加
- 迪拜
- 乌兹别克斯坦
- 哥斯达黎加
- 菲律宾
- 洪都拉斯
- 塞浦路斯
- 中国台湾
- 加纳
- 约旦
- 马尔代夫
- 卡塔尔
- 比利时



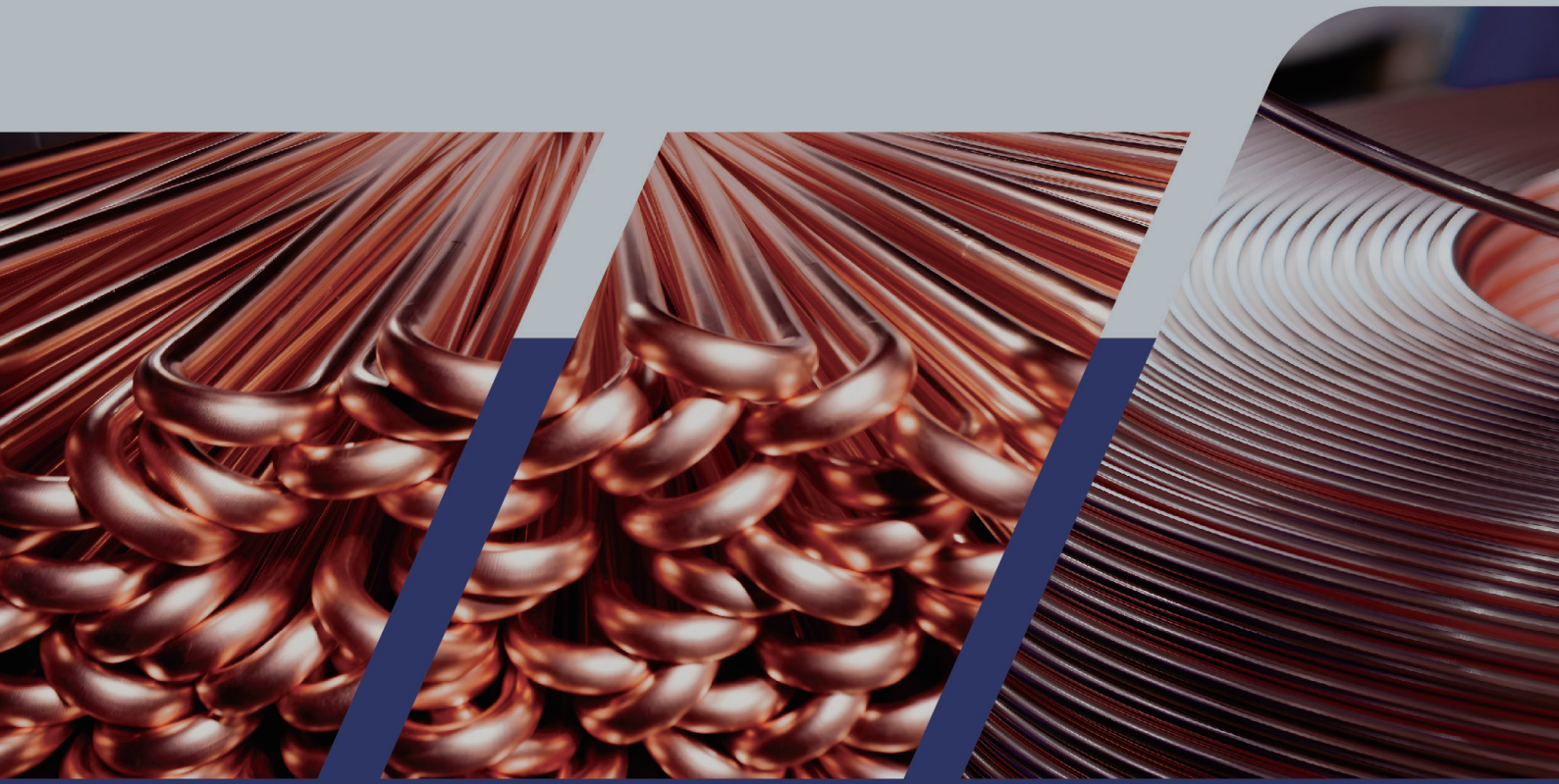

## 泰州伊士班尼亚制冷设备有限公司

地址:江苏省泰州经济开发区高新技术园标准厂房B区10号

电话:0523-80805003

传真:0523-80805666

手机:139-5117-1078; 132-2248-8188; 133-5779-8777

邮箱:taz39528116@126.com; 1367297073@qq.com; tzwdc@126.com

网址: <http://www.hispaniacorp.com>